

Electric Radiator

A cost effective approach to save fuel and reduce noise for generators from 2 to 10 kW

Description

An engine's belt driven or direct driven fan and water pump present a considerable parasitic loss in the generators fuel efficiency. Engine manufacturers typically size their fans (and water pumps) for the worst conditions: full load, hot weather, lowest engine speed, and this causes higher air velocities and pressure drops through the radiator.

The belt driven fan supplied with a 15 HP engine can consume as between 1.5 to 3 HP of the engines gross HP (equivalent to between 1.1 to 2.2 kW of power). Small increases in engine RPM can double the fan HP requirement, and this hurts the fuel efficiency of variable speed generators.

Polar's Electric Radiator starts with a large radiator core popular in 500+ HP racing cars. We need this large radiator because our design performance will be stationary as opposed to moving 200+ kilometers per hour in a racing car. Using a large radiator minimizes the air pressure drops through the radiator, allowing the use of more efficient fans. Also with the low air velocities and low volumes of air, we need a larger radiator to compensate for lower heat exchange efficiencies.

Low air velocities and air flow rates allow fans of very small power. So instead of using 1.1 to 2.2 kW we use only 100 to 120 watts. This is a considerable fuel savings and noise reduction.

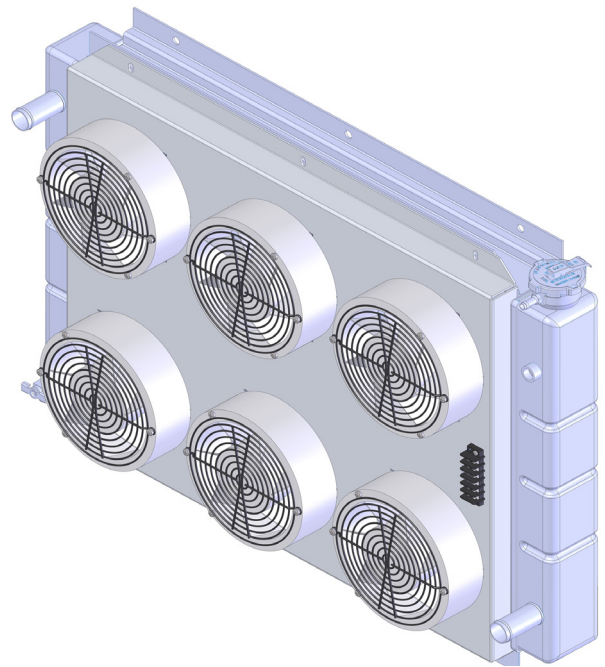

Description

Multiple fans are used for more efficient air flow distribution over the surface of the radiator and provide reliability through redundancy.

The vacuum dip, brazed, all aluminum, radiator core is more durable than the traditional soldered brass / copper radiators. This is one reason why most car companies have moved to this technology. To save cost most aluminum radiators use plastic header tanks as opposed to welded aluminum tanks. Plastic header tanks often crack or lose their seals after 3 years of service.

For durability and reliability Polar has chosen the more expensive design of all welded aluminum tanks.

Application Notes

The aluminum radiator has to have the correct antifreeze; using improper fluids will cause electrolyses that can destroy the radiator in a short time.

We recommend a 50/50 mix of water and coolant that is formulated for aluminum radiators and meets ASTM standards D336 and D4985. Extended life coolants can also be used if they meet the GM 6277 M DEX-COOL specification.

Premix formulations are the safest to use due to eliminating the need to add water, which varies depending on the location. If water is added, care needs to be taken to ensure it doesn't have a high solids content. Water can only maintain a certain percentage of dissolved solids, so if the water has too many solids already, then the corrosion inhibitors in the coolant may drop out which will reduce the corrosion protection.

Also, any water added needs to be between an 8 to 9 PH level. The coolant will shift to the low (acid) side as it is heated, so it's best to have the water slightly alkaline at an ambient temperature. This range should be confirmed with the coolant supplier.

It is very important to connect a grounding cable from the radiator to the engine block. With improper grounding your radiator can develop leaks in very short time.

For requirements exceeding 10 kW we have the option of using a fan tray assembly with stronger fans.

The electric radiator can be mounted external to the generator shelter to reduce the air flow requirement through the shelter. This will require a suitable outdoor enclosure to protect the assembly.

There are wind conditions that can stall the air flow through the radiator, so a cowl or shroud is recommended to protect the air exiting the radiator from being neutralized by the opposing natural wind.

Dimensions

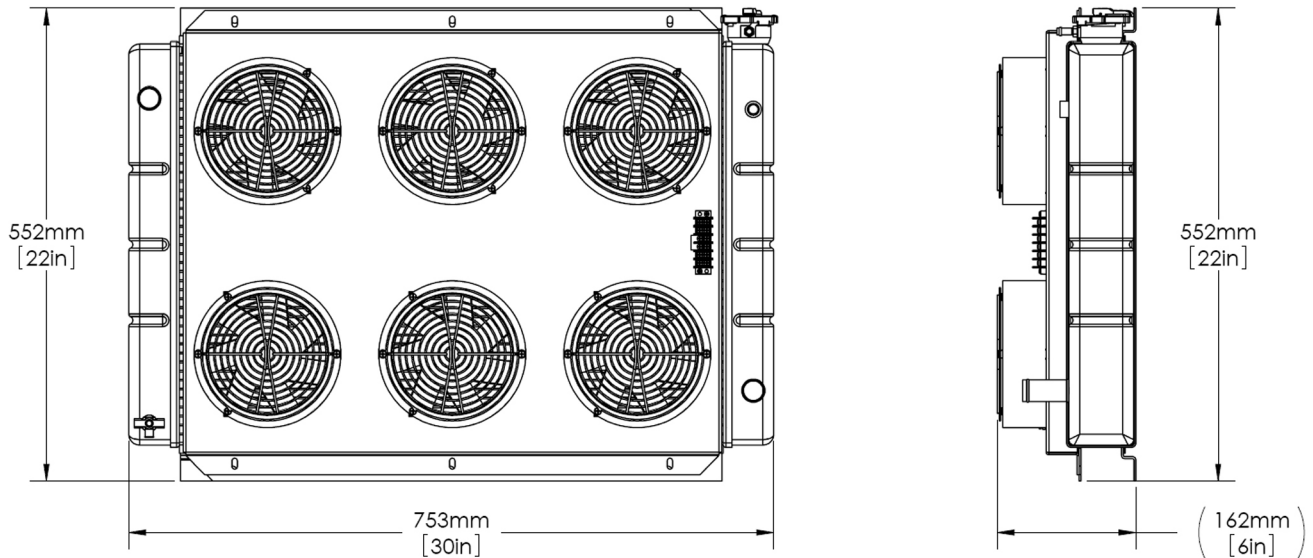

Specifications

Fans use brushless DC motors with ball bearings and provide an estimated life exceeding 20,000 hours.

Noise Level at 1 meter is approximately 60 dB(a).

Part Number	Voltage	Current	CFM	M ³ /hr
84-19-001-12	12 Vdc	12 Amps	1300	2200
84-19-001-24	24 Vdc	6.6 Amps	1500	2550
84-19-001-48	48 Vdc	2.4 Amps	1050	1800

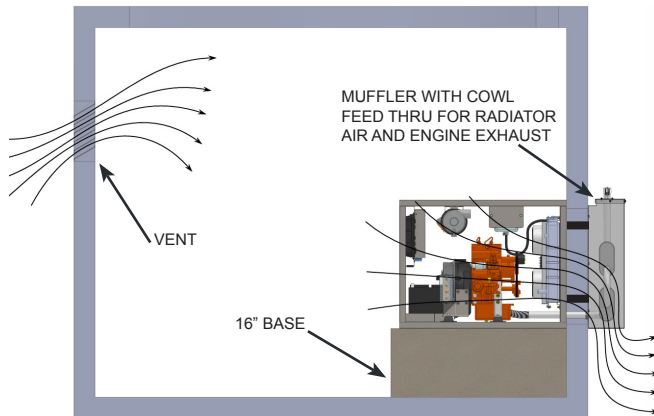

This installation configuration has the electric radiator mounted within the open frame assembly. Air is drawn into the shelter through louver in the shelter wall by the electric fans on the radiator. The electric fan pushes the cooling air through the radiator and exits the shelter directly. The volume of air moving through the air intake louver on the shelter wall has to satisfy both requirements of combustion air and radiator cooling. To simplify thermal insulation of the silencer /muffler and improve space inside the shelter the silencer is mounted external to the shelter. This is the most popular installation configuration as it keeps the generator and its fluids as one assembly within a frame.

Vent air requirements for cooling and combustion is a nominal:

- 1200 cfm - 6 kW and smaller
- 1500 cfm - 10 kW and smaller
- 1800 cfm - 17 kW and smaller

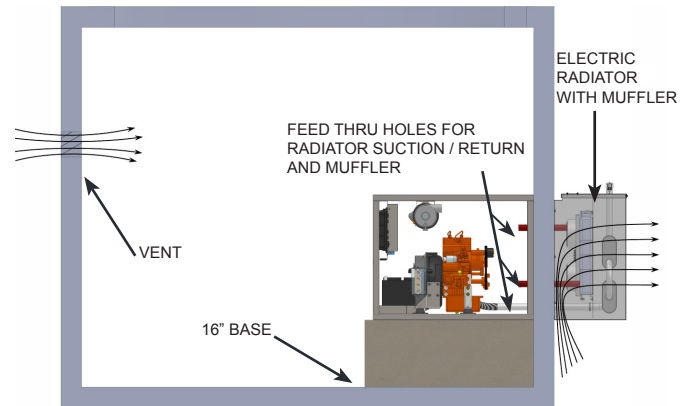

This installation configuration has the electric radiator and silencer / muffler assembly external to the shelter. This installation has popularity in very cold climates where there is the need to reduce the amount of low temperature air moving through the shelter. In this configuration only the combustion air and a very small amount cooling air is required from the vent on the wall.

Vent air requirements for cooling and combustion is a nominal:

- 300 cfm - 6 kW and smaller
- 450 cfm - 10 kW and smaller
- 600 cfm - 17 kW and smaller

Limited Warranty

Polar Power Inc. (hereinafter "Polar"), hereby warrants goods manufactured and sold by it to be free from defects in material and workmanship for 24 months after the date of shipment.

The warranty is limited to repair or replacement at 22520 Avalon Blvd., Carson, CA 90745 or other point designated by Polar of such parts as they appear to Polar, upon inspection, to be defective in material or workmanship. This warranty is extended to the first user only and no warranty is made or authorized to be made assignable on resale by the first end user.

The above warranty includes a pass-through warranty from the engine and controller manufacturers for whatever period and warranty is in effect by the manufacturer at that time. The above warranty only extends to applications and installations which are approved by mutual agreement between Polar and the first end users.

To obtain performance of any obligation under this warranty, contact must be made with Polar in writing at 22520 Avalon Blvd., Carson, CA 90745. Submission of a claim does not obligate Polar to accept such claim in full or in part.

No bills for service, labor or other expenses that have not been previously approved and authorized by Polar will be allowed.

No goods or materials may be returned until authorized in writing by Polar and, where the return of the material is authorized, it shall be F.O.B. to whatever point Polar designated within the U.S.A.

Repairs or alterations made to the goods without Polar written concurrence or the operation of the goods in excess of rated capacity will invalidate this warranty.

There is no implied warranty or condition of merchantability. There is no other warranty or condition expressed or implied, statutory or otherwise, except such as is expressly set forth herein. Neither Polar nor manufacturers will be liable for any general, consequential or incidental damages, including without limitation any damages for loss of use or loss of profits, for any breach of warranty or condition or for negligence; Polar's and manufacturer's liability and the buyer's exclusive remedy being expressly limited to the repair or replacement of the goods sold by polar as provided herein.